

Ancho nominal 95

Serie IBX

Para el correcto funcionamiento de las uniones deben respetarse las instrucciones de montaje.
Presión de prueba = 1,5 x PT

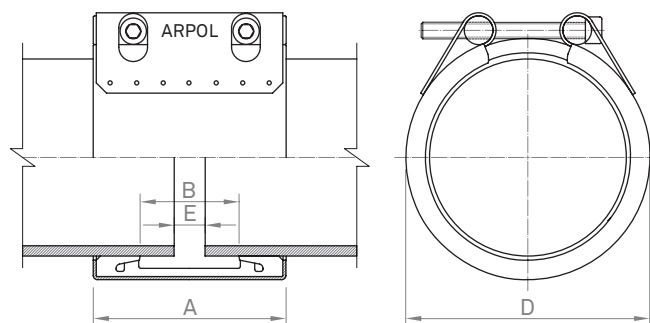

	Calidad W1		Calidad W2		Calidad W4		Calidad W5	
	AISI	DIN	AISI	DIN	AISI	DIN	AISI	DIN
Carcasa			304 L	1.4307	304 L	1.4307	316 L	1.4404
Tornillos			1035	1.0501	304	1.4301	316 L	1.4401
Ejes			1045	1.0503	304 L	1.4307	316 L	1.4404
Acero interior (cierre)			304 L	1.4307	304 L	1.4307	316 L	1.4404

Manguito de estanqueidad: EPDM / NBR / Silicona

DE	Rango	Presión		Dimensiones					Tornillos	
		PN bar	PT bar	A mm	B mm	D mm	E ¹ mm	E ² mm	Dia	Par Nm
48,3	47 - 49	16	45	78	31	67,3	5	15	M 8	7
54,0	53 - 55	16	45	78	31	73,0	5	15	M 8	7
57,0	56 - 58	16	40	78	31	76,0	5	15	M 8	7
60,3	59 - 61	16	40	78	31	79,3	5	15	M 8	7
63,0	62 - 65	16	40	78	31	82,0	5	15	M 8	7
76,1	74 - 77	16	30	94	45	98,1	5	15	M 8	7
84,0	82 - 85	16	30	94	45	106,0	5	15	M 8	7
88,9	87 - 91	16	30	95	45	110,9	5	15	M 8	7
104,0	102 - 106	16	30	95	45	126,0	5	15	M 8	10
108,0	107 - 111	14	30	95	45	130,0	5	15	M 8	10
114,3	112 - 117	13	30	95	45	136,3	5	15	M 8	10
125,0	124 - 127	12	20	95	45	147,0	5	15	M 8	10
129,0	127 - 131	12	20	95	45	151,0	5	15	M 8	10
133,0	131 - 136	11	20	95	45	155,0	5	15	M 8	10
139,7	137 - 142	11	20	95	45	161,7	5	15	M 8	10
154,0	152 - 156	10	20	95	45	176,0	5	15	M 8	10
159,0	156 - 161	10	20	95	45	181,0	5	15	M 8	10
168,3	166 - 171	10	20	95	45	190,3	5	15	M 8	10

E¹ separación admisible sin banda interior E² separación admisible con banda interior

PN presión nominal para industria naval con factor de seguridad ≥ 4 PT presión de trabajo DE diámetro exterior

DE	Máxima diferencia de diámetros	Máxima desviación angular	Máxima desalineación
mm	mm	grados	mm
48,3	0,5	4,0	1,0
54 - 63	1,0	4,0	1,0
76,1 - 104	1,5	4,0	1,0
108 - 154	2,5	4,0	1,0
159 - 168,3	2,5	4,0	2,0

Véase página 7 (Tolerancias admisibles)